

RM-3270W

Document P/N 821590 Rev-B

3U Dual LCD Video Monitor

with Two 7" (16:9) LCD Video Displays,
Four Composite Video Inputs (on BNC)
with A/B Switching, Four Loop-Through
Outputs (on BNC), and Option for
Adding SDI Inputs

User Manual

CONTENTS

<u>Title and Contents</u>	1
Introduction .and Important Safety Instructions	2
<u>Section 1: General Features and Specifications</u>	3
Description, Features, and Applications	4
Specifications and Options	5
<u>Section 2: Operation</u>	7
Front Panel Features	8
On-Screen Display Controls Operation	10
Rear Panel Features	12
<u>Section 3: Technical Information</u>	15
Tally Control Connector Wiring	16

Important Safety Instructions

- 1) Read these instructions.
- 2) Keep these instructions.
- 3) Heed all warnings.
- 4) Follow all instructions.
- 5) Do not use this apparatus near water.
- 6) Clean only with dry cloth.
- 7) Do not block any ventilation openings. Install in accordance with the manufacturer's instructions.
- 8) Do not install near any heat source such as radiators, heat registers, stoves, or other apparatus (including amplifiers) that produce heat.
- 9) Do not defeat the safety purpose of the polarized or grounding-type plug. A polarized plug has two blades with one wider than the other. A grounding type plug has two blades and a third grounding prong. The wide blade or the third prong are provided for your safety. If the provided plug does not fit into your outlet, consult an electrician for replacement of the obsolete outlet.
- 10) Protect the power cord from being walked on or pinched, particularly at plugs convenience receptacles and the point where they exit from the apparatus.
- 11) Only use attachments/accessories specified by the manufacturer.
- 12) Use only with the cart stand, tripod, bracket, or table specified by the manufacturer, or sold with the apparatus. When a cart is used, use caution when moving the cart/apparatus combination to avoid injury from tip-over.
- 13) Unplug this apparatus during lightning storms or when unused for long periods of time.
- 14) Refer all servicing to qualified service personnel. Servicing is required when the apparatus has been damaged in any way, such as when power-supply cord or plug is damaged, liquid has been spilled or objects have fallen into the apparatus, the apparatus has been exposed to rain or moisture, does not operate normally, or has been dropped.
- 15) Do not expose this apparatus to rain or moisture.
- 16) The apparatus shall be connected to a mains socket outlet with a protective earthing connection.

CAUTION!



In products featuring an audio amplifier and speakers, the surface at the side of the unit, where the audio amplifier heat sink is internally attached, may get very hot after extended operation. When operating the unit exercise caution when touching this surface and ensure that external materials which may be adversely affected by heat are not in contact with it. There is a Hot Surface label (see diagram) attached to the aforementioned surface of the product.

Introduction

Congratulations on your selection of a PANORAMAdtv product. We are confident it represents the best performance and value available, and we guarantee your satisfaction with it.

If you have questions or comments you may contact us at:

Wohler Technologies, Inc.

31055 Huntwood Avenue

Hayward, CA 94544

Phone: (510) 870-0810 Fax: (510) 870-0811

US Toll-Free: 1-888-596-4537

www.panoramadt.com sales@panoramadt.com

Section 1

General Features and Specifications

Description
Features
Applications
Specifications
Options

Unpacking

Unpack the **RM-3270W** unit from the shipping container and inspect all articles for shipping damage. If you find any damage, notify the shipping carrier immediately for claims adjustments. Compare the shipping box contents to the packing slip. Contact our PANORAMAdtv sales representative if there are any unexplained shortages.

Cooling and Airflow

No special physical mounting considerations are necessary regarding unit heat dissipation except under adverse conditions. Provided the ambient temperature inside the mounting enclosure does not exceed 40 degrees Celsius (104 degrees Fahrenheit), adjacent devices can be rack mounted (or stacked) in proximity to the **RM-3270W** unit. If the above temperature is exceeded, allow a 1RU (1.75"/25mm) space above and below the unit for air circulation.

Rack Mounting

The **RM-3270W** unit rack mounts in a standard EIA-310-D specification 19"/483 mm rack and needs 3RU of space. Allow sufficient space at the unit rear for connector and cable clearance (approximately 4"/102mm). The **RM-3270W** unit rack mounts from the front panel support rails. Rear support is not required. See page 14 for a top view of the unit showing width and depth clearance dimensions.

General Installation Recommendations

Recommended Cables: Recommended cable type for Composite (analog) or SDI video signals is: **Belden 1694A** (or equivalent).

RM-3270W

3U Dual LCD Analog/SDI Video Monitor

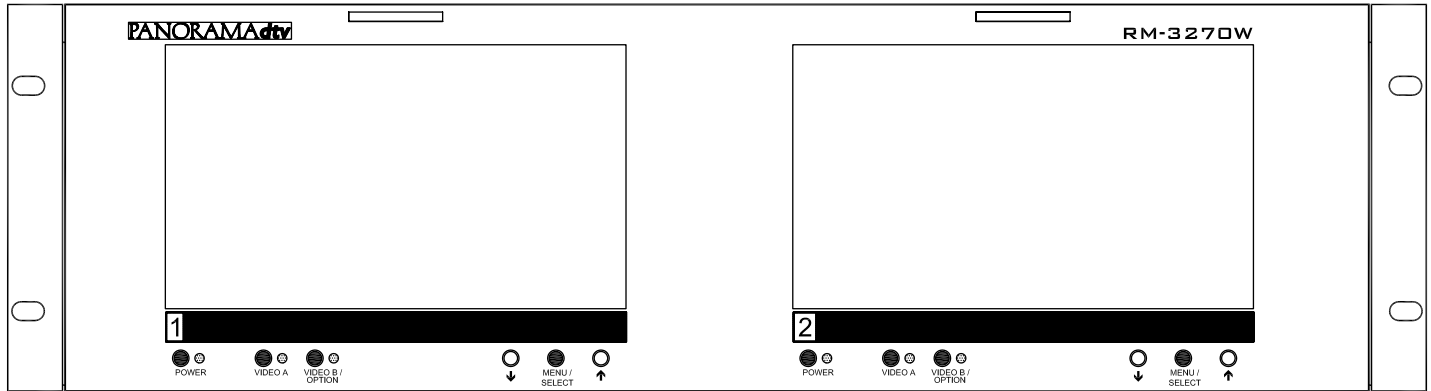

RM-3270W Front Panel

Description

The **RM-3270W** is a color video monitor with a 3RU front panel containing two 7" Widescreen Active Matrix TFT LCD displays (16:9 or 4:3 aspect ratio). Each LCD is back lit with a cold cathode fluorescent tube. The LCD's are mounted in a rotatable cylinder, which allows the operator to rotate the display array $\pm 55^\circ$ in the vertical plane to provide optimum operator viewing angles. Each LCD display has separate on-screen controls for brightness, contrast, color, tint (NTSC only), and a number of other parameters.

The standard **RM-3270W** unit features two **composite analog (CVBS)** video inputs per LCD display for a total of four inputs (NTSC and PAL autosensing). One of the two inputs (per display) is selected using two front panel buttons. Each of the four CVBS video inputs has a passive loop-through on a BNC connector and a 75 Ohm/Hi-Z termination select switch.

SDI signals may be monitored with installation of a field-installable option (one per display). There are two models of optional **SDI Input Module**; the **RMSDI-1** and **RMSDI-2**. The **RMSDI-2** features an **SDI input**, a relocked **SDI output**, a *converted* (from SDI) **CVBS output**, an **SDI Lock** indication LED, and autosensing of NTSC/PAL signal formats. The **RMSDI-1** offers a somewhat reduced feature set for cost savings and is identical except that it lacks the **SDI Output** and requires manually setting a switch for NTSC/PAL formatting. Selection of the **SDI Input Module(s)** is accomplished using the appropriate front panel A/B button.

Each display also features a tri-color (red/green/yellow) tally LED indicator. A DB25 connector on the rear panel is used to interface the **RM-3270W** with your facilities' tally system. An optional field-installable audio indication module (**AIM-1**) can be plugged into the tally connector in order to use the **RM-3270W** tally LEDs for indication of audio presence and loss.

Features

- Compact 3U rack size and lightweight
- Dual 7" Widescreen (16:9 or 4:3) LCD color video monitor
- Adjustable screen angle for efficient viewing
- four composite video inputs with loop-through (two per display)
- Front panel A/B selection (one per display)
- Dual standard NTSC/PAL auto-sensing
- On-screen controls for brightness, contrast, color, tint (NTSC), dimmer, frequency subcarrier, reverse image, zoom, etc.
- Two Red/Green/Yellow tally lights (one per display)
- Separate power button for each display
- Minimal power dissipation for low operating temperatures
- Low power consumption
- External power supply
- Optional (field installable) SDI input module(s) (**RMSDI-1** and **RMSDI-2**) with SDI input, relocked SDI output, converted CVBS output, and autosensing of NTSC/PAL formats
- Optional (field installable) audio indication module (**AIM-1**) for using the RM monitor tally lights to indicate audio presence or loss.

Applications

The **RM-3270W** is ideal for confidence video monitoring of multiple video feeds for mobile trucks, news and transmission control rooms, duplication and post production applications. Built and rigorously tested in the USA, the **RM-3270W** is backed by a strong warranty and a "Satisfaction Guaranteed" return policy.

Specifications

Video Input:	Four composite (CVBS) video inputs (two per screen) with A/B select. Each screen has provisions for an optional input module as the "B" input.
Video Input Termination:	Selectable 75 ohm termination
Video Output:	Four loop-through composite video outputs (two per screen)
Screen Type / Size:	Active matrix TFT-LCD / 7" diagonal
Source Selection:	A/B Selection of 2x CVBS IN (or 1x CVBS & 1x SDI module) per screen
Display Modes:	NTSC/PAL autosensing
Aspect Ratio:	16:9 and 4:3
Picture Controls:	Brightness, chroma, tint (NTSC only), contrast, reverse hoz/vrt, power savings, freq. subcarrier, zoom, aspect ratio
Resolution (dots x lines):	1440 x 234
Dot Pitch:	0.107 x 0.372 mm
Color Configuration:	RGB stripe
Viewing Angle:	top = 15 degrees, bottom = 35 degrees left = 60 degrees, right = 60 degrees
Contrast Ratio:	150 (typical)
Brightness:	400 NITs (cd/m ²)
LCD Lamp Life (at 50% of life):	10,000 hours (minimum) 15,000 hours (average)
Power Consumption:	25 watt (typical) 48 watt (max)
Power Supply:	110/220 VAC-12VDC, external power supply (included)
Chassis Type:	3U, 19" rack mounting (EIA-310D)
Dimensions:	18.8"W x 3.7"D x 5.2"H (483 x 94 x 132 mm)
Weight:	6 pounds (2.72 kg)

Options

RMSDI-1 (SDI) Input Option

Field installable SDI input module with SDI input, composite output of SDI input, SDI Lock LED, and manual NTSC/PAL switch

RMSDI-1 (SDI) Input Option

Field installable SDI input module with SDI input, SDI re-clocked output, composite output of SDI input, SDI Lock LED, and automatic NTSC/PAL sensing

AIM-1 Audio Indication Option

Field Installable Audio Indication Module (plugs into rear D-SUB and uses tally LEDs). Contact **PANORAMAdtv** directly for more information about this optional feature.

Call PANORAMAdtv or your distributor for ordering details on any of the options available for the **RM-3270W**.

Units are designed to meet, at time of manufacture, all currently applicable product safety and EMC requirements, such as those of UL and CE. Features and specifications subject to improvement without notice.

(This page intentionally left blank)

Section 2

Operation

Front Panel Features
On-Screen Display Controls Operation
Rear Panel Features

Front Panel Features

Please refer to **Figure-2a** on the following page to familiarize yourself with the front panel features of the **RM-3270W** unit. The following sections describe these functions and are referenced, by number, to **Figure-2a**.

1 Power Button (1-3)

These RED button switches are pressed to cycle each individual LCD display **ON/OFF**. The associated LED will glow GREEN to indicate the display section is powered ON.

2 A/B Source Select Buttons (A and B)

In a standard configuration, these dark GREY buttons select between the *primary* **CVBS (VIDEO A)** and *secondary* **CVBS (VIDEO B/OPTION)** video source inputs for the associated **I/O Section**. Selecting either button deselects the previously selected button.

If an optional **SDI Input Module (RMSDI-1 or RMSDI-2)** is installed in an **I/O Section**, the associated buttons selects between the primary **CVBS Input** source (**VIDEO A**) and the *installed* **SDI Input** video source (**VIDEO B/OPTION**).

The LED next to the associated button will glow GREEN to indicate the selected input source (**A** or **B**).

3 LCD Video On-Screen Display Controls (1-3)

Each LCD video display can be adjusted separately using the on-screen display controls. See page **10** for a description how to adjust these parameters. The following parameters may be adjusted using these three buttons:

- **Brightness** - adjust for desired screen brightness.
- **Contrast** - adjust for desired image scene, dark-to-bright contrast.
- **Color (Saturation)** - adjust for desired amount of image color saturation.
- **Tint (Hue)** - adjust for desired image color hue (NTSC only).
- **Dimmer Level** - 1 to 8.
- **Power Savings** - ON/OFF (turns monitor off if no video signal after 6 seconds, returns power at signal).
- **Frequency Subcarrier** - select **3.58 MHz** or **4.43 MHz** for frequency subcarrier.
- **Horizontal Normal** - reverses image horizontally.
- **Vertical Normal** - reverses image vertically.
- **Mode** - **NORMAL** (original aspect ratio), **ZOOM1** (arbitrary zoom in), or **FIT** (stretches image to fit screen).

4 LCD Video Display (1-3)

View input video sources here. Select one of two source inputs for each display by setting the **A/B Source Select Buttons (Item 2)** to the desired input (**VIDEO A** or **VIDEO B/OPTION**). A number of screen image parameters are adjustable using the on-screen display controls (see **Item 3**).

Note that when no source signal is being input to a powered display, a "**NO SIGNAL**" message will show in the display screen until a source signal is applied.

5 Tally Indication LED (1-3)

This tri-color LED can glow RED, GREEN, or YELLOW to indicate tally status associated with the signal displayed. Refer to pages **16** and **17** for tally connection details.

An optional audio indication module (**AIM-1**) may be installed into the **Tally Control Connector** on the rear panel (**Item E**, page **12**), which allows these LEDs to act as audio indicator lights. Please contact **PANORAMAdtv** for more information about this optional feature.

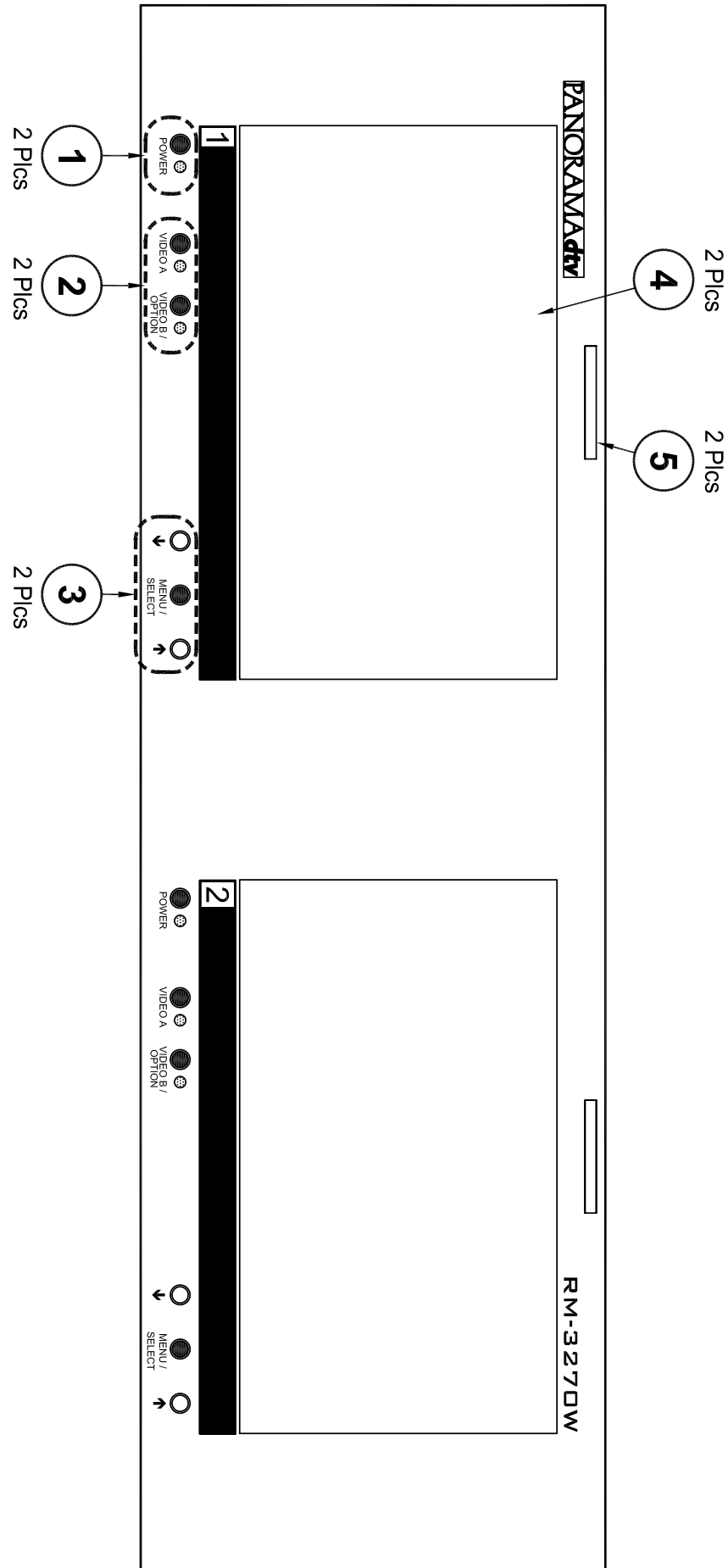

Figure-2a: Front Panel Features

On-Screen Display Controls Operation

Display controls for each of the two 7" LCD Video Displays are viewed on-screen and set via the two WHITE buttons (↑ and ↓) and one BLACK button (**MENU/SELECT**) beneath the respective display (See **Item 3**, page 8). Parameters are manipulated as described below:

BRIGHTNESS

Press the **UP** and **DOWN** buttons directly to increase and decrease the LCD display **BRIGHTNESS**. The image below will be displayed on-screen while adjusting to indicate the level.



COLOR / CONTRAST / TINT

- 1) Press the **MENU** button to access the **Main Menu** onscreen.
- 2) Press the ↑ and ↓ buttons to *scroll* through the options.
- 3) Press the **MENU** button to *select* the chosen parameter for adjustment.
- 4) Press the ↑ and ↓ buttons to *adjust* the level.
- 5) Press the **MENU** button to *return* to the **Main Menu**.
- 6) To *exit* the menu, use the ↑ and ↓ buttons to select **EXIT** and then press the **MENU** button.

NOTE: The **TINT** parameter is applicable **ONLY** when monitoring **NTSC** video source signals.

The onscreen menu and parameters for **COLOR**, **CONTRAST**, and **TINT** controls are shown below:

COLOR
Adjustment:

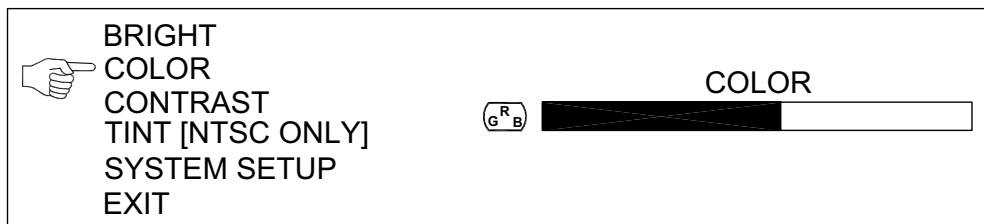

CONTRAST
Adjustment:

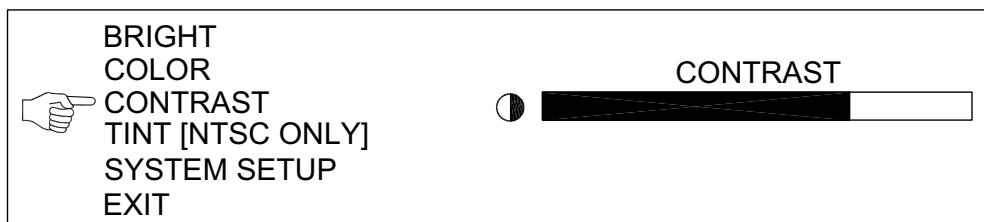

TINT
Adjustment:

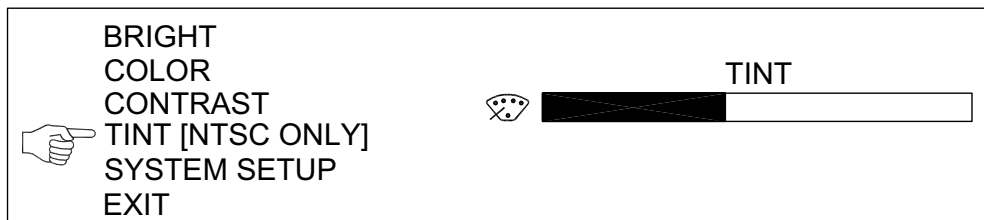

(Continued)

LCD Video Display On-Screen Controls

(Continued)

SYSTEM SETUP

To enter the **System Setup** submenu, choose **SYSTEM SETUP** in the **Main Menu**, and press the **MENU** button.

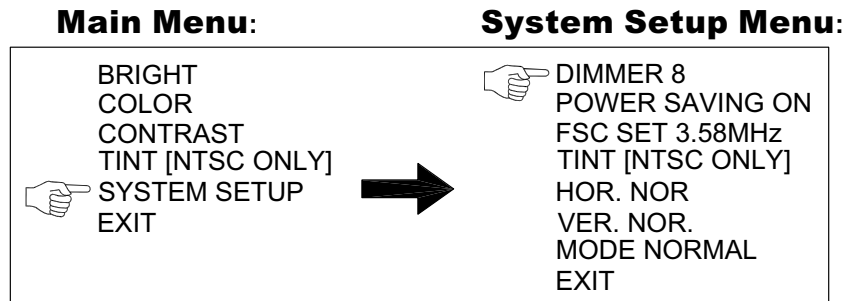

Use the **UP** and **DOWN** buttons to select the **System Setup** option as shown below.



DIMMER 8

- 1) Press **MENU** button to select **DIMMER 8** option.
- 2) Press **↑** and **↓** buttons to select **Dimmer** level from **0** to **8**.
- 3) Press **MENU** button to activate selection.



POWER SAVING ON

- 1) Press **MENU** button to select **POWER SAVING ON** option.
- 2) Press **↑** and **↓** buttons to select **POWER SAVING ON** or **POWER SAVING OFF**.
- 3) Press **MENU** button to activate selection.

When the display is set up with **Power Saving Mode ON**, power will automatically turn off after 6 seconds if there is no video signal entering the display. Power will automatically turn as soon as a video signal is detected.



FSC SET 3.5MHz

- 1) Press **MENU** button to select **FSC SET 3.5MHz** (**Frequency Subcarrier**) option.
- 2) Press **↑** and **↓** buttons to select **FSC SET 3.58MHz** or **FSC SET 4.43MHz**.
- 3) Press **MENU** button to activate selection.

This option will force the **Frequency Subcarrier** of the display at **3.58MHz** or **4.43 MHz**.



HOR. NOR.

- 1) Press **MENU** button to select **HOR. NOR.** (**Horizontal Reverse Image**) option.
- 2) Press **↑** and **↓** buttons to reverse the image *horizontally*.
- 3) Press **MENU** button to activate selection.



VER. NOR.

- 1) Press **MENU** button to select **VER. NOR.** (**Vertical Reverse Image**) option.
- 2) Press **↑** and **↓** buttons to reverse the image *vertically*.
- 3) Press **MENU** button to activate selection.



MODE NORMAL

- 1) Press **MENU** button to select **MODE NORMAL** option.
- 2) Press **↑** and **↓** buttons to select **NORMAL**, **ZOOM1**, or **FULL**.
- 3) Press **MENU** button to activate selection.

NORMAL mode will display images in original aspect ratio of source (example: 4:3 ratio displayed undistorted in 16:9 screen with blank space on either side). **ZOOM1** mode zooms into center area of display. **FULL** mode forces aspect ratio of source to conform to 16:9 aspect ratio (example: 4:3 ratio displayed in 16:9 screen stretched [distorted] to fill entire display).



EXIT

Press **MENU** button to select **EXIT** option, press **MENU** button again to return to **Main Menu**.

Rear Panel Features

Please refer to **Figure-2b** on the following page to familiarize yourself with the rear panel features of the **RM-3270W** unit. The following sections describe these features and are referenced, by letter, to **Figure-2b**. See **Figure-2c** on page 14 for a top view of the **RM-3270W** showing rear panel connector clearance dimensions.

Note about options: **Figure-2b** shows an **RM-3270W** rear panel with each of the two optional **SDI Input Modules (RMSDI-1 and RMSDI-2)** installed in channels 1 and 2 and a rear panel without options installed. The **SDI Input Modules** may be installed in any combination (one per display). The installed options are selected for monitoring by pressing the associated **VIDEO B/ OPTION Button** on the front panel (**Item 2**, page 8). For each section with an **SDI Input Module** installed, the **CVBS Loop-Through Connector (Item C)** will output **CVBS** signals as converted from the **SDI** input. In any I/O section with an **SDI Input Module** option installed, the **"B" CVBS Input BNC** connector should NOT be used, and it is recommended that it be covered with a connector cap to prevent its use.

A Termination Switch (1A - 3A, 1B - 3B)

This switch terminates the **CVBS Input Connector** as required by your configuration. If you supply downstream equipment from the **CVBS Loop-Through Connector (Item C)**, then set this switch to the **Hi-Z** position. If *not*, set this switch to the **75Ω** position.

B CVBS Input (IN) Connector (1A - 3A, 1B - 3B)

CVBS video signals may be connected here. **NTSC** or **PAL** standards are accommodated automatically. If signals are connected at both the **"A"** and **"B"** inputs within the same I/O section, use the **A/B Source Select Buttons (Item 2**, page 8) to select between the two. **Note:** If an **SDI Input Module** is installed in a given section, do NOT use that **"B"** **CVBS** input.

C CVBS Loop-Through (OUT) Connector (1A - 3A, 1B - 3B)

Signal-through connections to downstream equipment are supplied at these **BNC** connectors. If you supply downstream equipment from these connectors, ensure that you set the appropriate **Termination Switch (Item A)** according to your configuration. Note that if an **SDI Input Module (Item G)** is installed in the same I/O section, this connector outputs a **CVBS** signal as *converted* from the **SDI Input Connector (Item Gc)**.

D Option Connector (1-3)

This **DE9** (9-pin) female connector allows you easily install an optional **SDI Input Module (Item G)**.

E Tally Control Connector

This 25-pin subminiature female "D" connector allows you to use the four front panel **Tally Indication LEDs (Item 5**, page 8). Full connection instructions are described on pages 16 and 17.

F Power Connector

Attach the supplied 110/220-12V external power supply between this connector and mains power.

G Optional SDI Input Modules (RMSDI-1 and RMSDI-2)

There are two models of optional **SDI Input Module**; the **RMSDI-1** and **RMSDI-2**. They are identical except that the **RMSDI-1** does *not* feature a **SDI Output Connector (Item Gb)** and must use the **525/625 Select Switch (Item Ge)** to select the **NTSC/PAL** format of the input signal (the **RMSDI-2** does this automatically).

Note: See **Figure-2c** on page 14 for depth clearance dimensions of **RM-3270W** when **RMSDI** option modules are installed.

Ga CVBS Output (Converted From SDI Input) Connector

When an **SDI Input Module (RMSDI-1 or RMSDI-2)** is installed, this connector outputs **CVBS** signals as *converted* from the **SDI Input Connector (Item Gc)**. If this output is NOT used, set the associated **Termination Switch (Item A)** to **75Ω**.

Gb SDI Output Connector (RMSDI-2 Only)

SDI signal-through connections to down-stream equipment are supplied at this **BNC** connector. This connector supplies a reclocked replica of the **SDI** input signal.

Gc SDI Input Connector

Connect **SDI** signals to this female **BNC** connector, which is terminated at **75Ω**.

Gd SDI Lock Indication LED (GREEN)

When a valid (and locked) **SDI** signal is received at the **SDI Input Connector (Item Gc)** this LED lights GREEN.

Ge 525/625 (NTSC/PAL) Select Switch (RMSDI-1 Only)

On the **RMSDI-1** (only), this switch is used to manually select for **NTSC** (525 line) or **PAL** (625 line) input signals. Set the switch to the **RIGHT** to select **PAL** (625 lines), to the **LEFT** to select **NTSC** (525 lines).

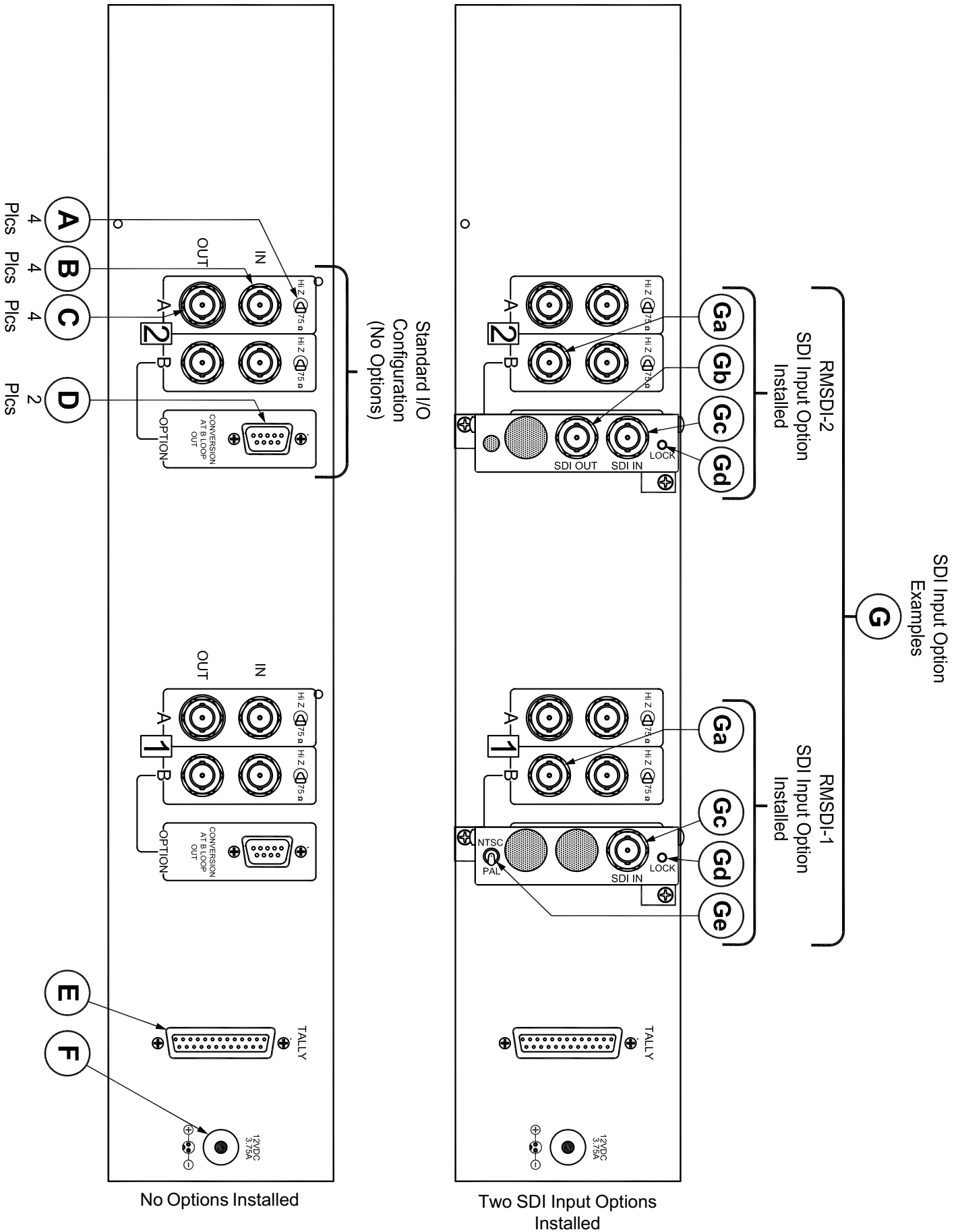

Figure-2b: Rear Panel Features

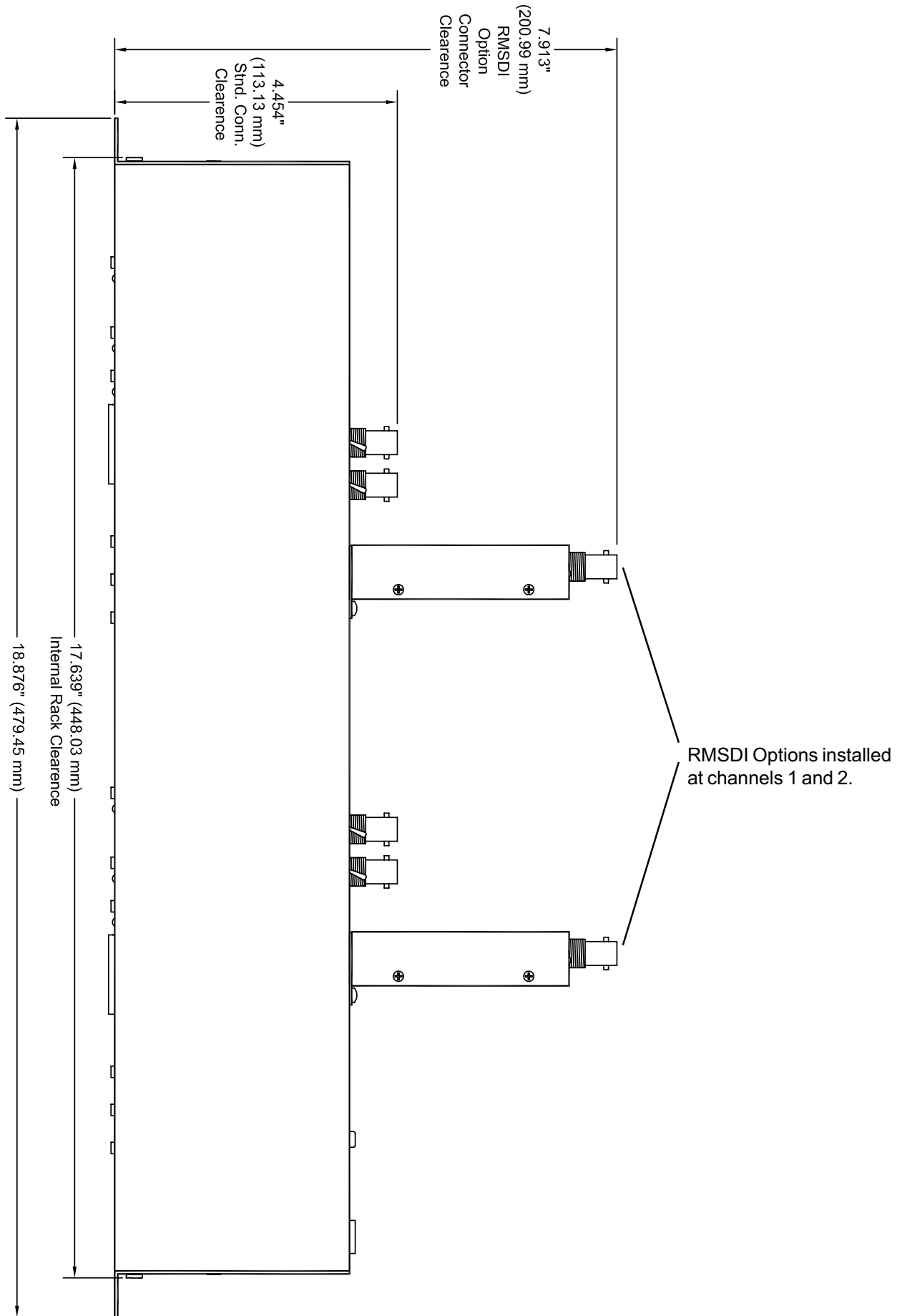

Figure-2c: RM-3270W Top View (Depth and Width Clearance Dimensions)

Section 3

Technical Information

Tally Control Connector Wiring

Tally Control Connector Wiring

A front panel tally LED is associated with each LCD monitor. Interface is provided to the LEDs via the **Tally Control Connector** on the rear panel (**Item E**, page 12). Tri-color (RED, GREEN, and YELLOW) tally indications are achievable by activating the red and green LED sections simultaneously. For connection details, see **Figure-3a** below .

Figure 3-b, on the facing page, shows sample tally connection configurations. You can operate the Tally LEDs by three methods. The three tutorial examples showing **Dry Closure** (internal power), **Positive True Logic Drive** (external power), and **Open Collector** (transistors as switches) are illustrated to show basic operation.

The Tally indicators are capable of displaying three colors. Illuminating the RED or GREEN LEDs separately will result in that tally color. Illuminate the RED and GREEN LEDs simultaneously to achieve a YELLOW tally.

Isolated

Operating the Tally LEDs in an *isolated* configuration (**Figure-3b: Dry Closure**) requires an external (customer provided) power supply and tally system. If your facility currently has a tally system with companion power source, use this method to integrate the RM Monitor tallies with your existing tally matrix.

NOTE: Ensure the LED power supply provides +5 to +12VDC.

Non-Isolated

Operating the Tally LEDs in the *non-isolated* configuration (**Figure-3b: Positive True Logic Drive**) uses the **RM Monitor** internal power supply to provide the tally LED voltage. Connect your tally closures as shown in **Figure-3b** to the respective **RM Monitor** tally connections.

Audio Indication Module Option

An optional audio indication module (**AIM-1**) is available to enable the use of the tally LEDs to indicate audio presence and loss. The **AIM-1** module installs onto the **RM** rear panel tally connector and then receives the audio input from a separate cable. Contact PANORAMAdtv for more information concerning this option.

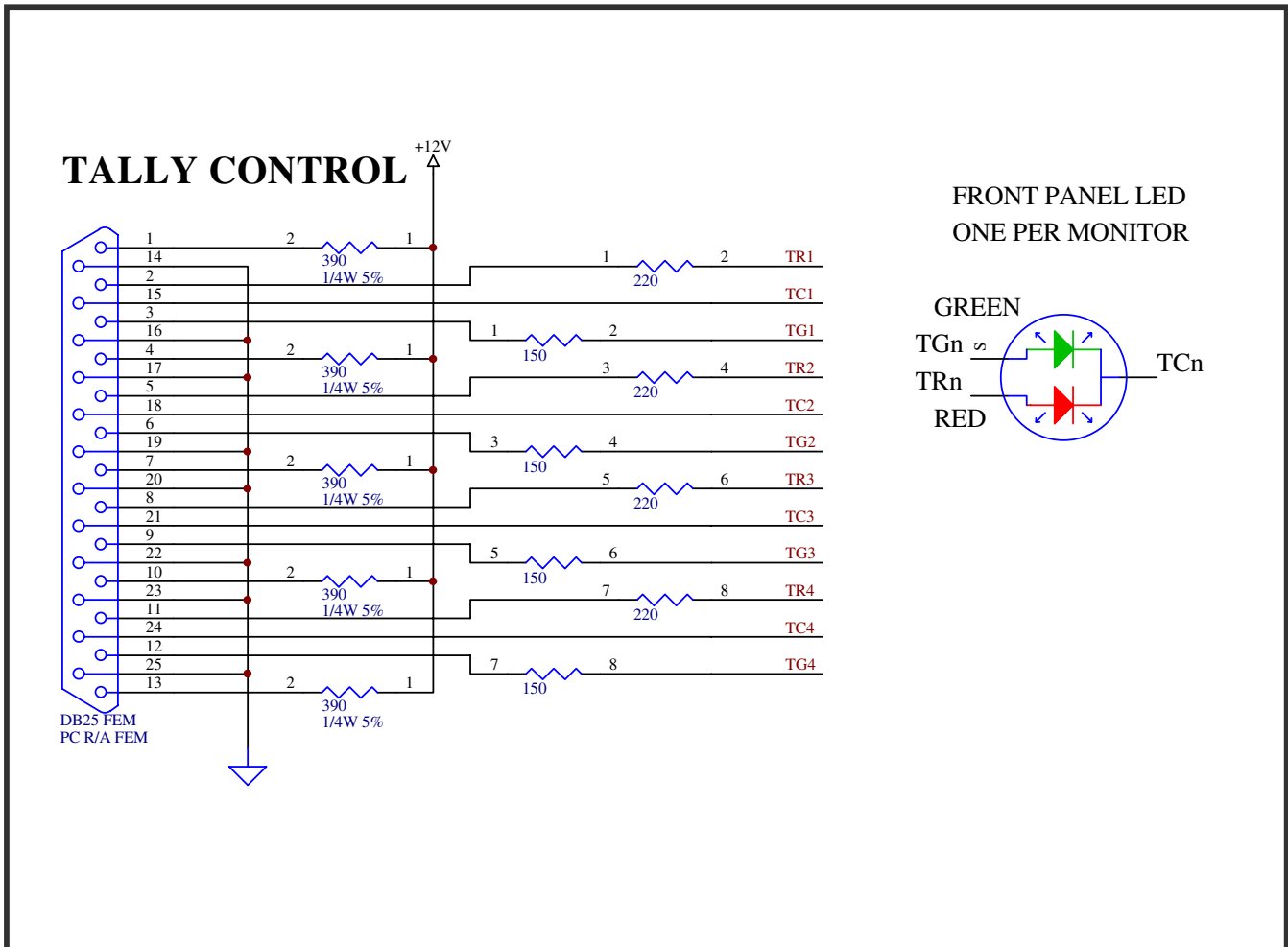

Figure-3a: RM Monitor Tally Control Connector Pin Function

Tally Control Connector Wiring

DRY CLOSURE

USING INTERNAL POWER SOURCE

(EITHER/OR BOTH LEDS ON IS OK, BOTH = YELLOW)

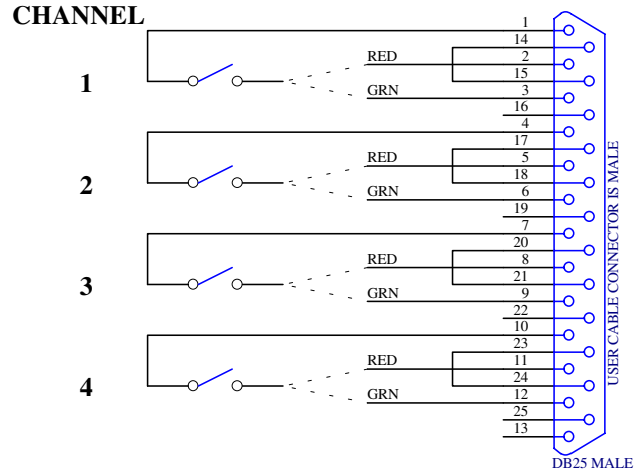

POSITIVE TRUE LOGIC DRIVE

USING EXTERNAL POWER 5 - 12VDC

(EITHER/OR BOTH LEDS ON IS OK, BOTH = YELLOW)

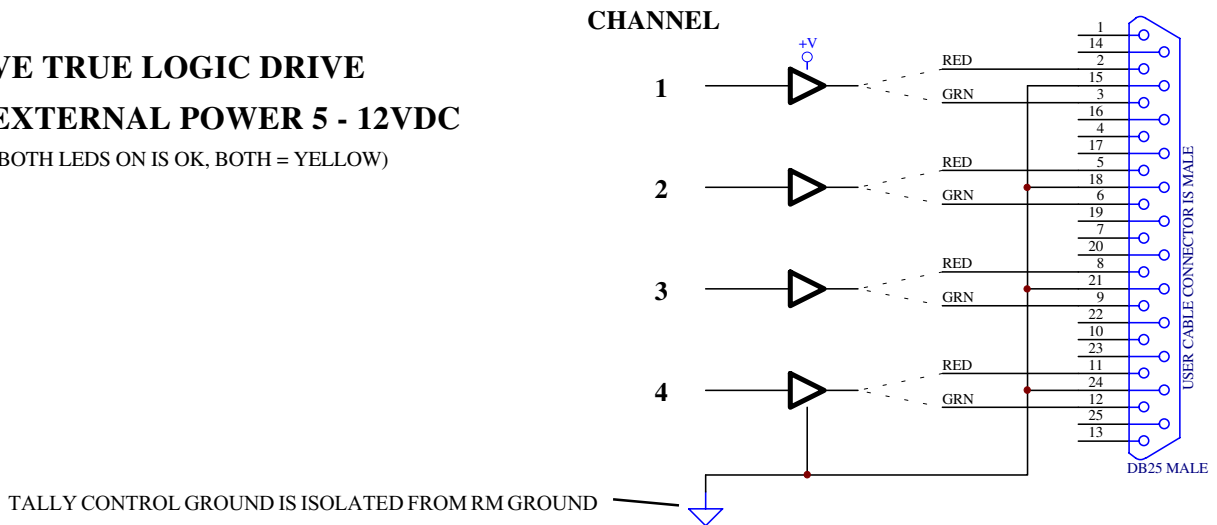

OPEN COLLECTOR

TRANSISTOR ON =LED ON

(ONE LED ONLY)

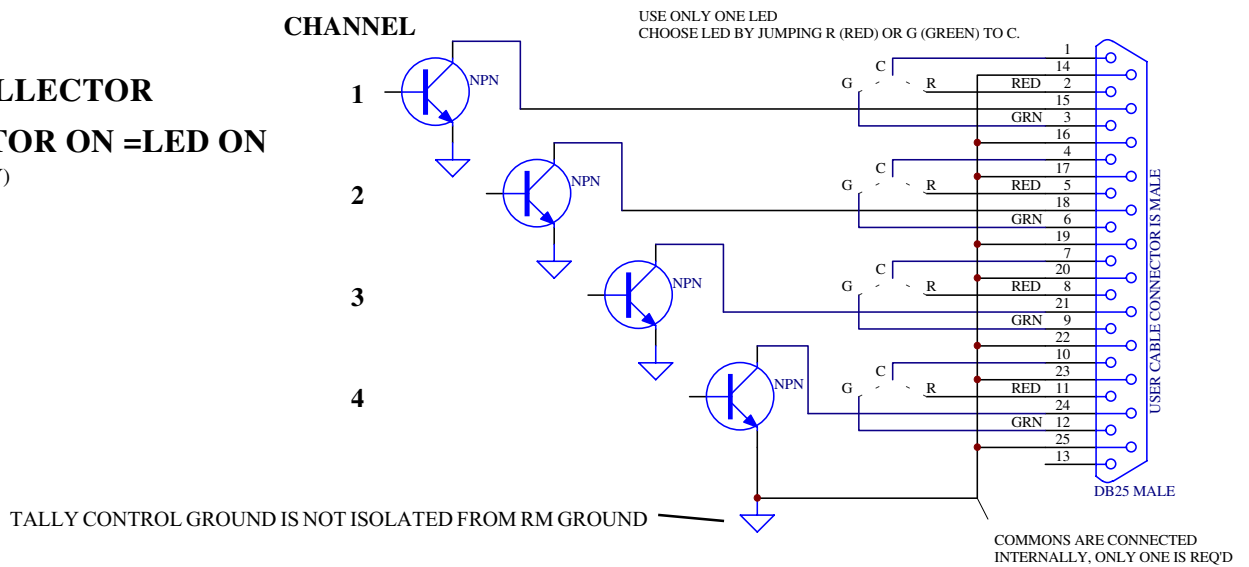

Figure-3b: RM Monitor Sample Tally Connections



Wohler Technologies, Inc.

31055 Huntwood Avenue

Hayward, CA 94544

Phone: (510) 870-0810 Fax: (510) 870-0811

US Toll-Free: 1-888-596-4537

www.wohler.com support@wohler.com